



# XSLAN

## SHDSL Switch

---

### USER GUIDE

---

The XSLAN SHDSL switch is designed and manufactured by

**ETIC TELECOM**  
405 rue Lavoisier  
38330 MONTBONNOT SAINT MARTIN  
FRANCE

TEL : + (33) (0)4-76-04-20-05  
E-mail : [hotline@etictelecom.com](mailto:hotline@etictelecom.com)  
web : [www.etictelecom.com](http://www.etictelecom.com)

# DECLARATION OF CONFORMITY

The manufacturer, ETIC Telecom – 405 rue Lavoisier – 38330 Montbonnot Saint Martin – France, Hereby declares under sole responsibility that the listed products conform to

- the Electromagnetic Compatibility (EMC) Directive 2014/30/UE ,
- the Low Voltage Directive (LVD) 2014/35/UE ,
- the Restriction of the use of certain Hazardous Substances (RoHS) Directive 2011/65/UE.

**Type of product:** SHDSL switch

**Models:**

XSLAN-1400, XSLAN-1220

XSLAN-2400, XSLAN-2220

XSLAN-BP2400, XSLAN-BP2220

XSLAN-4200, XSLAN-BP4200

The harmonized standards to which these products comply are:

Standard	Title
EN 61000-6-2 2006	Immunity: EN61000-4-2 Electrostatic Discharge EN61000-4-3 RF Radiated Immunity EN61000-4-4 EFT/Burst Immunity EN61000-4-5 Surge Immunity EN61000-4-6 RF Conducted Immunity EN61000-4-8 Power Frequency Magnetic Field Immunity
EN 61000-6-4 2007 A1/2011	Emission: EN55032 Radiated and conducted emission
EN 62368-1 2014	Safety and Health

Date : 16th March 2023

Philippe Duchesne  
Technical Director



**NOTE:**

**This equipment has been tested and found to comply with the limits for a Class A digital device, pursuant to Part 15 of the FCC Rules. These limits are designed to provide reasonable protection against harmful interference when the equipment is operated in a commercial environment. This equipment generates, uses, and can radiate radio frequency energy and, if not installed and used in accordance with the instruction manual, may cause harmful interference to radio communications. Operation of this equipment in a residential area is likely to cause harmful interference in which case the user will be required to correct the interference at his own expense.**



<b>OVERVIEW</b> .....	<b>7</b>
1 Purpose of this manual .....	7
2 Products Identification .....	7
3 Specifications .....	9
4 EMC & Environment compliances.....	11
5 Product overview .....	13
5.1 XSLAN-1XXX .....	13
5.2 XSLAN-2XXX .....	13
5.3 XSLAN-4200.....	15
6 Highlighted features .....	17
6.1 STU-C / STU-R auto-negotiation .....	17
6.2 Redundancy solutions: RSTP and proprietary failsafe ring.....	17
6.3 The by-pass function .....	18
6.4 The loop VPN function .....	18
6.5 MACSec secure link.....	19
6.6 Other functions of the XSLAN family .....	19
<b>INSTALLATION</b> .....	<b>21</b>
1 Description .....	21
1.1 Dimensions .....	21
1.2 Sides.....	22
1.3 Connectors.....	23
1.4 Push button.....	25
1.5 LED indicators.....	25
2 Safety instructions.....	26
3 DIN rail mounting .....	26
4 cooling .....	26
5 Power supply.....	26
6 Isolation and earthing .....	27
7 RS232 serial connection (XSLAN-X220) .....	27
8 RS485 serial connexion (XSLAN-X220).....	27
9 Digital input and output .....	28
10 Preparing and checking the line.....	28
10.1 Type of cable.....	28
10.2 Crosstalk interference .....	28
10.3 Shield earthing .....	29
10.4 Protecting the SHDSL switch from lightning .....	29
11 Connecting the XSLAN to the line.....	29
11.1 General precautions.....	29
11.2 Point to point connection using two, three or four twisted pairs.....	29
11.3 Daisy chain or ring connection.....	30
<b>PREPARING THE SETUP</b> .....	<b>31</b>
1 Connecting a PC for configuration .....	31
1.1 Overview.....	31
1.2 First configuration .....	32
1.3 Modification ultérieure de la configuration.....	32
2 Temporary return to the factory settings .....	33

## TABLE OF CONTENTS

3	Restoring the factory settings.....	33
4	Protecting the access to the administration server.....	34
5	Configuration steps .....	34
	<b>ANNEX 1 : SHDSL data rate versus distance .....</b>	<b>35</b>

# OVERVIEW

## 1 Purpose of this manual

The present user guide describes the features and the installation of the XSLAN switches family with the exception of the XSLAN-1100 model.

In the rest of the document the term " XSLAN " is used to designate the product.

## 2 Products Identification

The XSLAN is an industrial Ethernet switch that provides 1 to 4 SHDSL ports to extend the Ethernet transmission up to several kilometers using any existing copper pair.

The XSLAN switches family consists of these models :

XSLAN-1400, XSLAN-1220  
 XSLAN-2400, XSLAN-2220  
 XSLAN-BP2400, XSLAN-BP2220  
 XSLAN-4200, XSLAN-BP4200

The main features are summarized hereafter :

XSLAN models								
	1400	1220	2400	2220	BP2400	BP2220	4200	BP4200
SHDSL port	1	1	2	2	2	2	4	4
Max. data rate (Mb/s)	15.2	15.2	30.4	30.4	30.4	30.4	60.8	60.8
Ethernet port 10-100 Mb/s	4	2	4	2	4	2	2	2
RS232/RS485 *	N	Y	N	Y	N	Y	N	N
By-pass	N	N	N	N	Y	Y	N	Y
Failsafe ring	N	N	Y	Y	Y	Y	Y	Y
Serial gateway raw, telnet, modbus, unitelway	N	Y	N	Y	N	Y	N	N

XSLAN models

XSLAN-1400



XSLAN-1220



XSLAN-2400



XSLAN-2220



XSLAN-BP2400



XSLAN-BP2220



XSLAN-4200



XSLAN-BP4200





### 3 Specifications

General characteristics	
Dimensions	137 x 51 x 142 mm (h, w, d)
Weight	Max 0.74 kg
Casing	Metallic IP21 – IEC60529 DIN rail mounted
Temperature	Storage: -40°/ +85°C Operating: -40°/ +70°C
Humidity	5 to 95 % relative (non-condensing)
Alimentation	Protected against reverse polarity Nominal : 12-24 VDC (min 10 VDC - max 30 VDC) 2 points Phoenix type connector
Consumption	XSLAN-1400, XSLAN-1220 : 3W XSLAN-2400 XSLAN-2220 : 4W XSLAN-4200 : 6W
MTBF	>500 000 h at 25 °C - MIL-HDBK-217F-N2 GB
Electrical safety	IEC/EN 62368-1
Hazardous substances	2011/65/UE (RoHS) REACH

SHDSL	
Modulation	ITU-T G.991.2, 802.3ah: 2BaseTL (EFM)
Data rate	192 kb/s to 15,2 Mb/s on 1 pair
Emission power	Annex A: 13.5 dBm (22 mW) Annex B: 14.5 dBm (28 mW)
Voltage of the emitted signal	6 to 8 V peak to peak on 135 Ohms
Signal spectrum	< 3 MHz at 15 Mb/s
Isolation	1500 V
Connection time	45 s typical
Plug & play	STU-C / STU-R auto-negotiation Automatic adaptation of the data rate
Latence	Transmission delay for a 256 bytes frame from one Ethernet port of an XSLAN to the Ethernet port of another XSLAN through an SHDSL link: < 2 ms at 5.6 Mb/s

## OVERVIEW

ETHERNET & IP	
Ethernet	10/100 Mb/s Half/Full duplex Auto MDI/MDIX
Switch	Store and forward - 1024 addresses MAC
Redundancy	RSTP - IEEE 802.1D / 802.1Q Fail safe ring Loop VPN
VLAN	IEEE 802.1Q
IP address	IPV4 and IPV6
IP router	LAN – SHDSL routing Multicast and broadcast filtering Static routes RIP V2 - OSPF
Multicast	RFC 4541 IGMP Snooping
QOS	RFC 2474, 2475, 2597, 2598 « Differentiated services » Traffic prioritization and bandwidth reservation
Security	MACSec : IEE 802.1AE. Encryption : AES256 mode GCM on SHDSL traffic 802.1X & Radius : Authentication on Ethernet ports

Serial gateways	
Gateways	Raw TCP client Raw TCP server Raw UDP Raw Multicast Modbus TCP client to Modbus RTU/ASCII slave (for master PLC) Modbus TCP server to Modbus RTU/ASCII master (for slave PLC) Telway/XIP to Unitelway slave (for master PLC) Telnet RFC 2217
RS232/RS485	Data rate: 1200 to 115200 kb/s, 10 or 11 bits, parity N / E / O RS232: RJ45 RS485: 2 points Phoenix type connector

Misc.	
SNMP	SNMP V2 and V3 Supported MIBs: RFC1213-MIB (MIB-2) HDSL2-SHDSL-LINE-MIB HOST-RESOURCES-MIB / IF-MIB IP-MIB BRIDGE-MIB RSTP-MIB Traps SNMP
Date and time	NTP client and server
Configuration	HTTP and HTTPS server SSH console
Log	Log with timestamp of the last 300 events Syslog
Management	Import and export configurations Reset product to return to factory configuration
Alarm	1 digital output

**4 EMC & Environment compliances**

EMC Immunity, EN61000-6-2			
Standard	Criteria	Port	Level passed
EN61000-4-2 ESD	B	Enclosure	+/-4kv contact +/-8kv air discharge
EN61000-4-3 Radiated	A	Enclosure	10V/M AM @ 1khz 80Mhz to 3Ghz
EN61000-4-4 Burst	B	SHDSL	+/- 2kv
		Power supply	+/- 2kv
		Ethernet	+/- 2kv
EN61000-4-5 Surge	B	SHDSL	+/- 5kv common mode (Normal and Telecom surge)
	B	Power supply	+/- 0,5kV common mode +/- 0,5kV differential mode
		Ethernet	+/- 4kv direct shield coupling
EN61000-4-6 RF conducted	A	SHDSL	10VAM 80% 1khz, 150khz to 80Mhz
		Power supply	
		Ethernet	
EN61000-4-8 Magnetic	A	Enclosure	30 A/M at 50hz/60hz
EN61000-4-18 Damped wave	A	Power supply	+/- 0,5kV differential
	B		+/- 1kV common mode
	A	Ethernet	+/- 1kV common mode
	B	SHDSL	+/- 1kV common mode

EMC Immunity, ITU -T-K21			
Test	Criteria	Port	K44 Test N°
Lightning voltage, special test protector	A	SHDSL	2.1.2a +/- 5kV transverse mode (Basic level)
			2.1.2b +/- 5kV port to earth (Basic level)

EMC Emissions, EN61000-6-4		
Emission test	Port	Limits
Conducted disturbance	Power supply	EN55032, Class A: 150khz to 30Mhz
	SHDSL	
	Ethernet	
Radiated emission	Enclosure	EN55032, Class A: 30Mhzto 1Ghz

## OVERVIEW

Climatic		
Standard	Test	Level
EN 60068-2-1 Cold	Ab	-40 °C - 16 hours – Non-operating
	Ad	-40 °C - 16 hours – Operating
EN 60068-2-2 Dry heat	Bb	+85 °C - 16 hours – Non-operating
	Bd	+70 °C - 16 hours – Operating
EN 60068-2-14 Change of temperature	Na	-25 °C to +70 °C – Non-operating 5 cycles of 2 hours
	Nb	-20 °C to +60 °C – Operating 1 °K/mn - 5 cycles of 2 hours
EN 60068-2-30 Damp heat	Db Variante 2	+25 °C à 55 °C – Operating 2 cycles

## 5 Product overview

The XSLAN switches family includes :

### The products which can be connected to only one twisted pair.

They only provide one SHDSL interface.

The references of that products are XSLAN-1400 or XSLAN-1220 depending on whether or not they provide serial ports.

They are named XSLAN-1XXX hereafter.

### The products which can be connected to two twisted pair.

They provide two SHDSL interfaces.

The references of that products are XSLAN-2400, XSLAN-BP2400, XSLAN-2200 or XSLAN-BP2220 depending on whether or not they have serial ports and by-pass.

They are named XSLAN-2XXX hereafter.

### The products which can be connected to four twisted pair.

They provide four SHDSL interfaces.

The references of that products are XSLAN-4200 or XSLAN-BP4200 depending on whether or not they have a by-pass.

## 5.1 XSLAN-1XXX

### Point to point link on a single twisted pair

Two XSLAN-1XXX extend Ethernet over one twisted pair.

The data rate is up to 5,7 Mb/s on 3,7 Km and 15 Mb/s on 0,7 Km (see table in Annex 1).

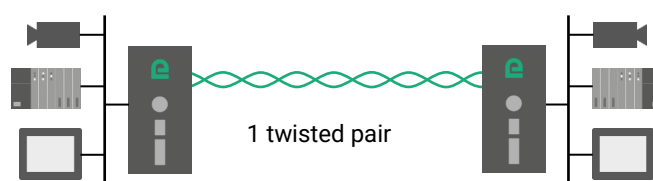

## 5.2 XSLAN-2XXX

Additional features compared to XSLAN-1XXX:

### Point to point link on two twisted pairs

Two XSLAN-2XXX extend Ethernet over two aggregated twisted pairs.

The data rate is twice the data rate on a single pair: up to 11,4 Mb/s on 3,7 Km and 30 Mb/s on 0,7 Km (see table in Annex 1).

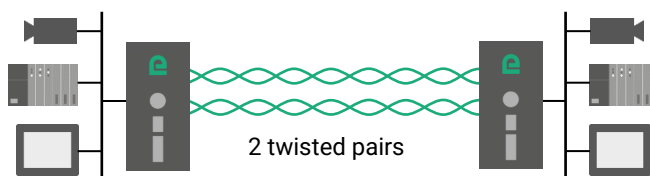

In case of a failure of a pair the data transmission is maintained on the other pair (backup).

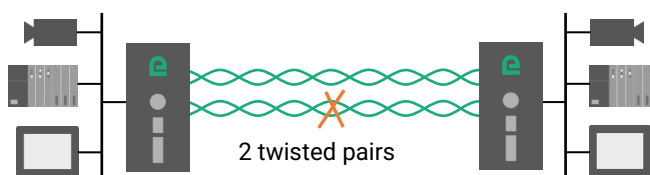

# OVERVIEW

## Daisy chain link

The XSLAN-2XXX allows you to interconnect a series of Ethernet networks using a single twisted pair. Thanks to the Store and Forward principle, the number of switches is not limited.

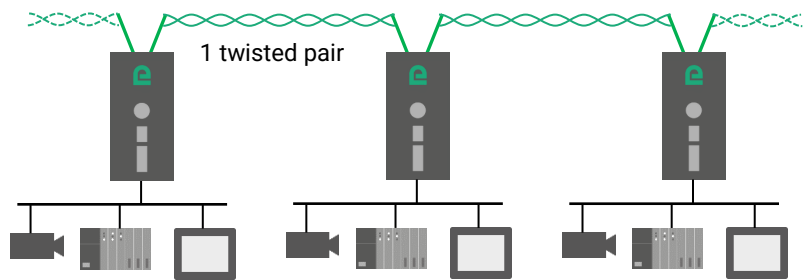

## Point to multipoint link

The XSLAN-2XXX allows you to interconnect a central site with two remote sites.

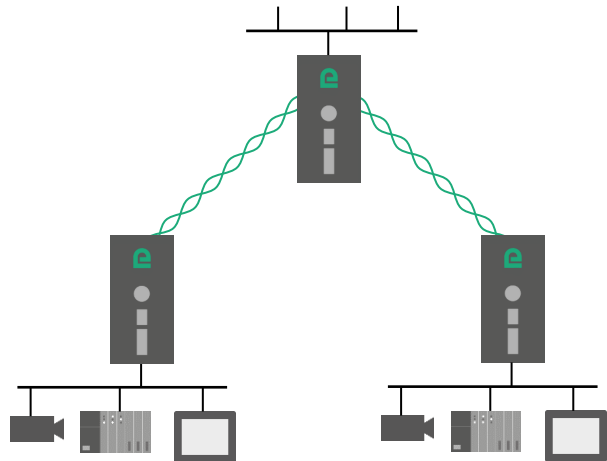

**RSTP redundant link of fail safe ring**

Redundant network ring using the proprietary protocol (or RSTP)

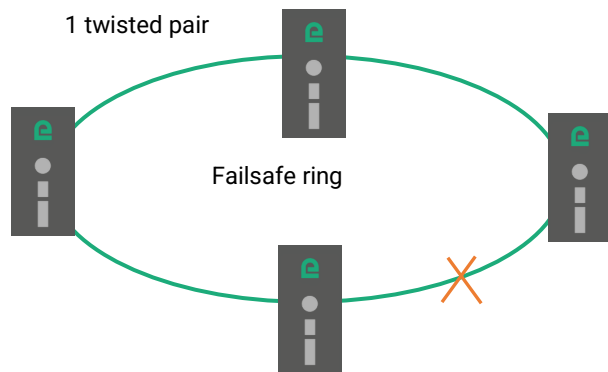

Complex network topology and "multi-manufacturer" using the RSTP standard protocol.

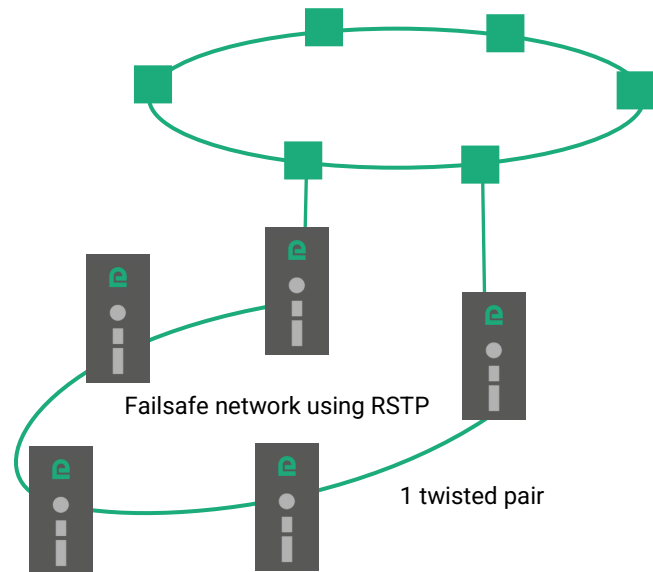

**5.3 XSLAN-4200**

Additional features compared to XSLAN-2XXX:

**Point to point link on four twisted pairs**

Two XSLAN-4200 extend Ethernet over two, three or four aggregated twisted pairs.

The data rate is the sum of the data rate on each pair: up to 22,8 Mb/s on 3,7 Km and 60 Mb/s on 0,7 Km (see table in Annex 1).



In case of a failure of one or more pairs, the data transmission is maintained on the remaining pairs (backup).

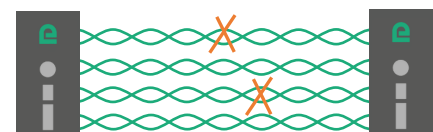

# OVERVIEW

## Point to multipoint link - Concentrator

The XSLAN-4200 allows you to interconnect a central site with four remote sites..



## Point to multipoint link with doubled data rate

The XSLAN-4200 allows you to interconnect a central site with two remote by aggregating pairs 2 by 2.

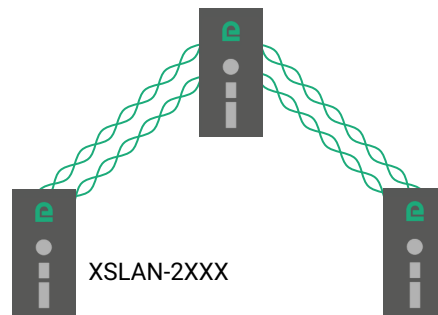

## Redundant ring with doubled data rate

The XSLAN-4200 allows you to create a secure ring with doubled data rate by aggregating pairs 2 by 2.

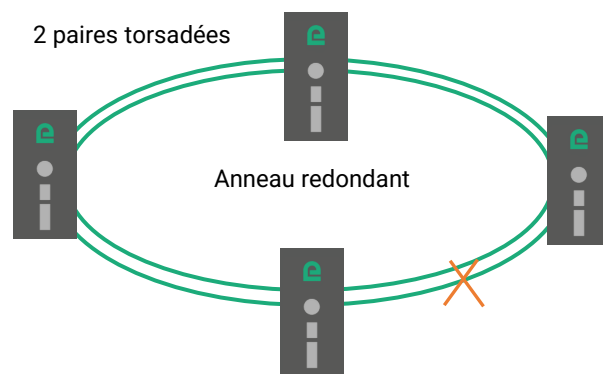



## 6 Highlighted features

### 6.1 STU-C / STU-R auto-negotiation

When two XSLAN are connected by a twisted pair, one switch initiates the connection while the other responds and adapts automatically its data rate.

The switch that initiates the connection is called STU-C.  
The switch that responds and adapts is called STU-R.

Thus a line is always connected on one side to a switch acting as the STU-C and on the other side to a switch acting as the STU-R.

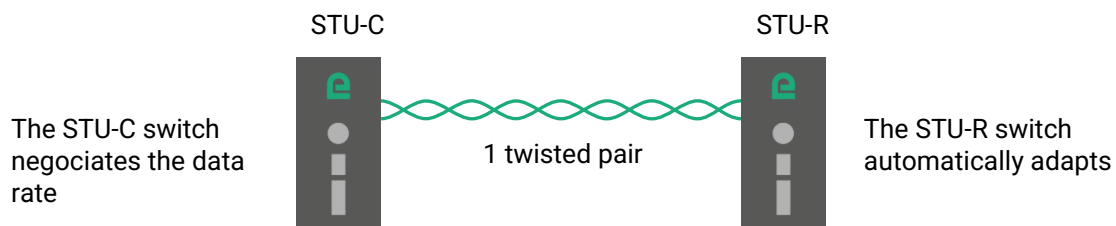

**One switch is normally configured as a STU-C and the other as a STU-R. However, to make the configuration simpler, the switch configured as a STU-C is able to automatically change to STU-R mode if it detects the presence of a STU-C on the remote side. Thus, two XSLAN configured both in STU-C will find a way to connect. One of the two will switch to STU-R.**

### 6.2 Redundancy solutions: RSTP and proprietary failsafe ring

Industrial applications need reliable networks; one way to provide reliability is to provide backup paths which form loops in the Ethernet network.

However, loops are highly unwelcome in Ethernet networks, as they can cause broadcast storms, eating up all the available bandwidth and causing network outage.

The goal of redundancy protocols is to make Ethernet work of networks containing loops and to provide a path at each time, even, if possible, when one or several links are in failure.

The XSLAN provides two solution to handle redundancy :

#### **RSTP :**

RSTP, standing for "Rapid Spanning Tree Protocol" is specified by the IEEE in the 802.1D-2004 document.

RSTP can handle complex structures ; RSTP can be used with devices from other manufacturers.

The failure detection delay and the recovery delay in an SHDSL network is around 10 seconds.

#### **Proprietary failsafe ring algorithm:**

Based on the STP algorithm, that solution makes possible to handle a ring structure up to 16 SHDSL switches.

The advantages of that solution is that the failure detection delay and the recovery delay is only a few seconds (One second if the ring counts 5 SHDSL switches); moreover, it is very simple to configure.

## OVERVIEW

### 6.3 The by-pass function

When the network is a daisy chain – that case is very frequent in industrial applications - and when, however, it is not possible to build a failsafe structure like a ring, the XSLAN-BP offers a very useful function called the “By-pass function”.

The XSLAN-BP includes an electro-mechanical relay between both lines; that relay is automatically closed to connect the two lines when the XSLAN-BP is switched off.

For instance, if the XSLAN #2 cabinet is switched off for maintenance, the by-pass relay inside the XSLAN #2 will automatically connect the line coming from the XSLAN #1 to the line going to the XSLAN #3.

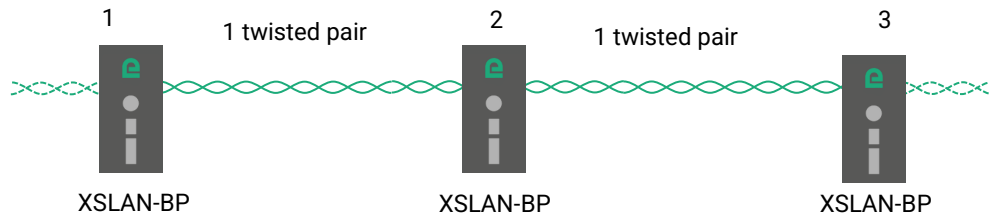

After a few seconds, the XSLAN #1 detects the connection default and establishes immediately the connection with the XSLAN #3.

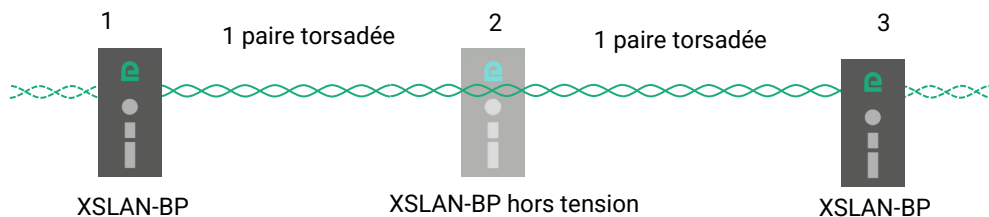

### 6.4 The loop VPN function

When the SHDSL network forms a daisy chain (ie a linear topology), and when it is not possible to form a secure ring, the "loop VPN" function allows for network redundancy if a public WAN connection (Internet) or private (MPLS) is available at each end of the SHDSL network.

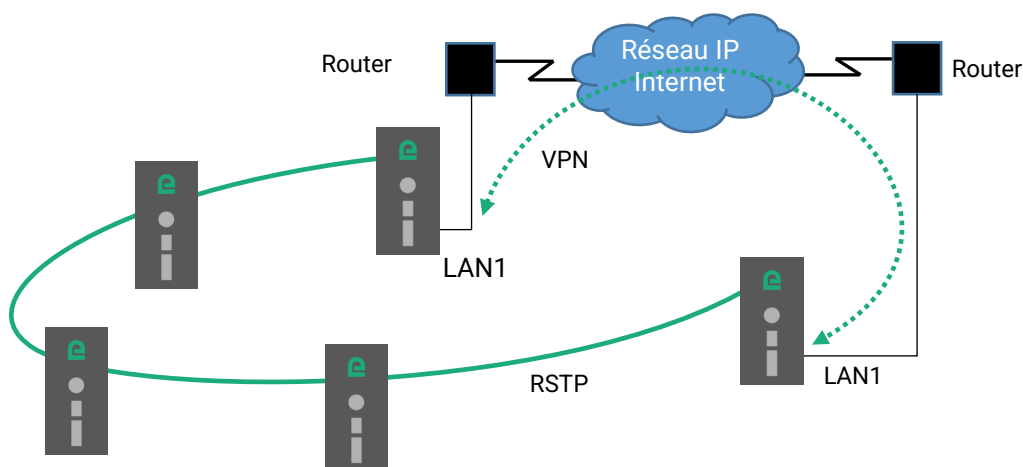

The 2 XSLAN at the end of the network establish a VPN over the WAN. The VPN provides connectivity at the Ethernet level. Thus by activating the RSTP redundancy may be provided thanks to that VPN.

## 6.5 MACSec secure link

Media Access Control security (MACsec) is defined by IEEE standard 802.1AE and provides point-to-point security on SHDSL links

MACsec operates at the medium access control layer and defines connectionless data confidentiality and integrity for media access independent protocols.

MACSec allows frames egressing an SHDSL port to be enciphered and signed. Frames ingressing an SHDSL port will be deciphered and authenticated.

Two XSLAN-1400 allow the interconnection of two Ethernet networks by means of a secure SHDSL link. Thus it is not possible to intercept the traffic even by inserting a spy device on the SHDSL line.

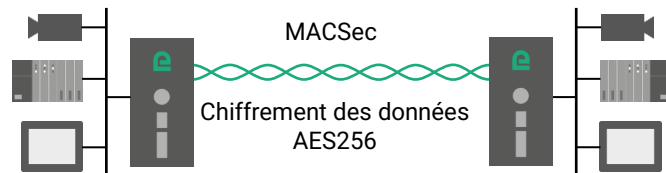

An XSLAN-4200 can secure or not each of its 4 SHDSL links independently.

An XSLAN-2400 can secure or not each of its 2 SHDSL links independently.

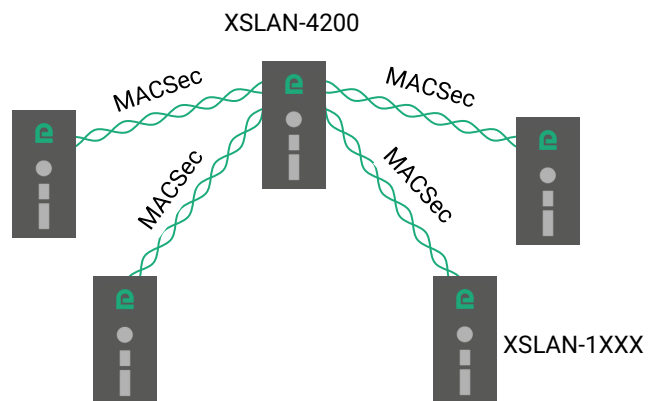

## 6.6 Other functions of the XSLAN family

### Data rate versus distance

The table in Annex 1 gives the data rate which can be expected over a line versus the length of the line. Each interface features an adaptive data rate from 192 Kb/s up to 15,2 Mb/s.

When using several aggregated pairs, the total data rate that can be obtained is equal to the sum of the data rates on each pairs.

### Ethernet and serial interface

Depending on the model, the products have either 4 RJ45 Ethernet interfaces, or 2 Ethernet and 1 or 2 serial interfaces associated with a gateway function that allows the easy integration of equipment with RS232 or RS485 or RS422 serial interface to the Ethernet network.

### IP routing and filtering

The XSLAN can remove the broadcast frames on the SHDSL link by routing the IP frames, and thus limiting the unwanted traffic on the SHDSL link.

### VLAN

The XSLAN features VLAN :

Each Ethernet port can be assigned to a particular VLAN. A device connected to an Ethernet port belonging to a particular VLAN can communicate only with devices connected to Ethernet ports belonging to the same one.

## OVERVIEW

### **Quality of service DiffServ**

The XSLAN can manage different IP traffics with different priorities.

### **802.1X**

The XSLAN manages the authentication of devices connected to its Ethernet ports by querying a central Radius server.

### **SNMP**

The XSLAN can be monitored by an SNMP manager and supports the main MIB of an Ethernet switch and the SHDSL MIB.

### **Configuration**

The products are configured using a browser in HTTP or HTTPS.

# INSTALLATION

## 1 Description

### 1.1 Dimensions

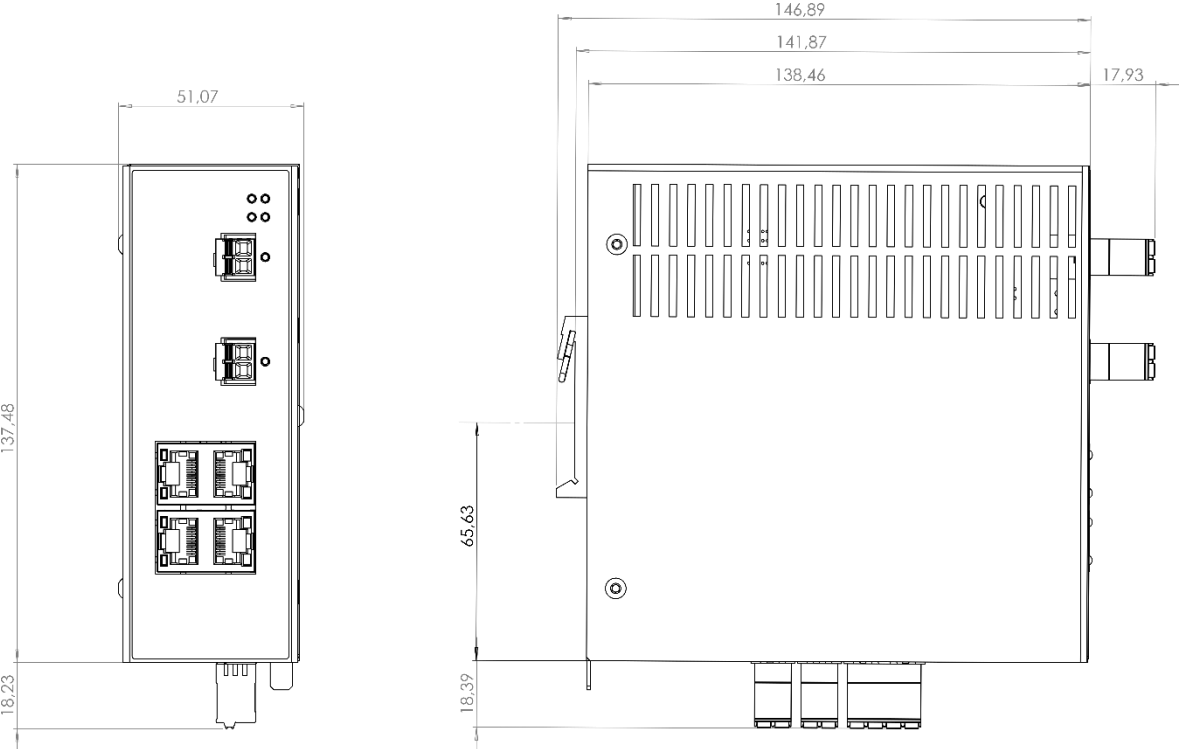

All dimensions in millimeters.

# INSTALLATION

## 1.2 Sides

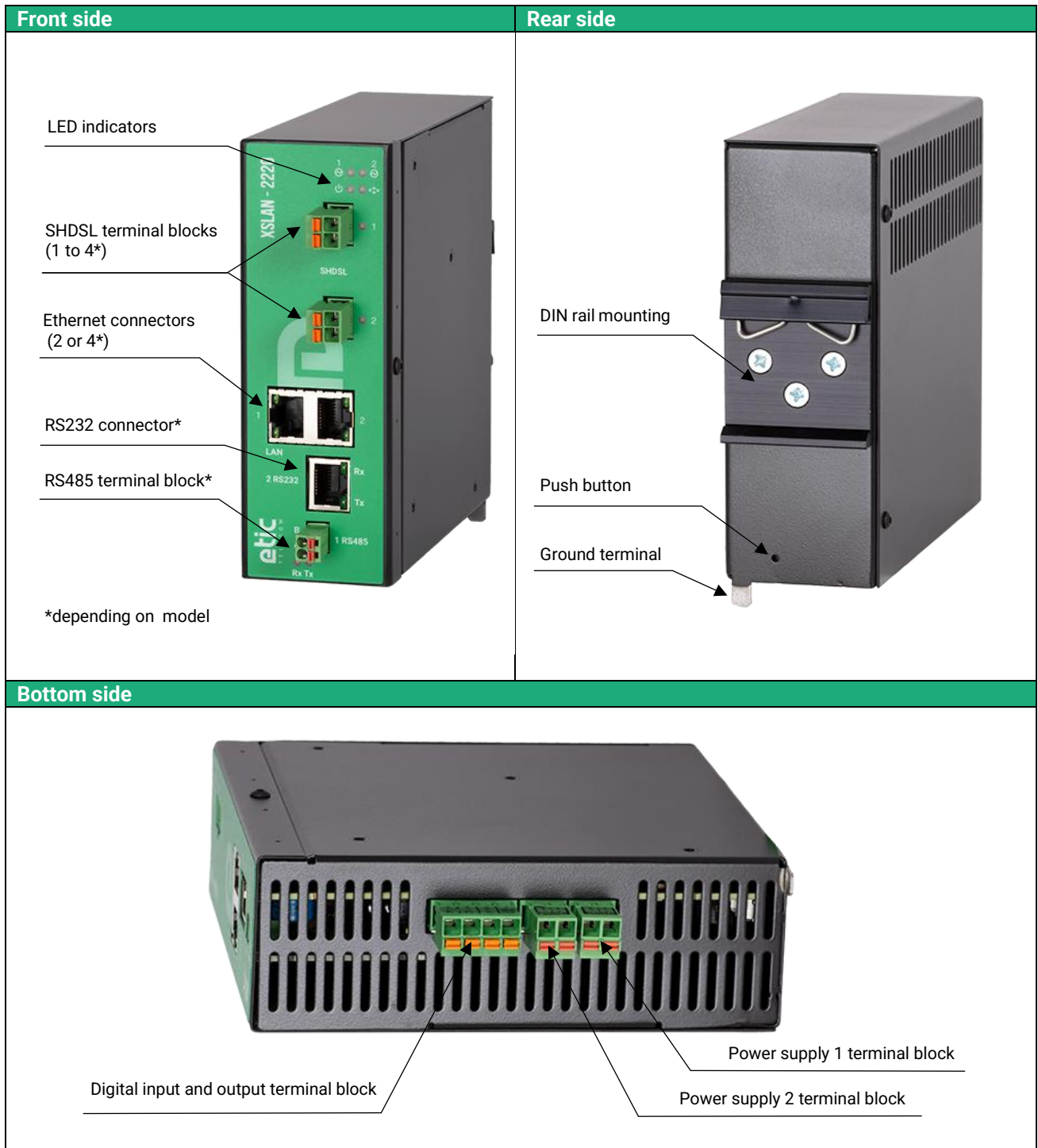

1.3 Connectors

Ground terminal	
Symbol	Description
	FASTON male lug 6.35 mm

2 positions terminal block : Power supply 1 Position 1 at back – Protected against reverse polarity		
Position	Signal	Function
1	Power +	12 – 48 V DC
2	Power -	0V isolated from the enclosure

2 positions terminal block : Power supply 2 Position 1 at back – Protected against reverse polarity		
Position	Signal	Function
1	Power +	12 – 48 V DC
2	Power -	0V isolated from the enclosure

4 positions terminal block : Digital input and output Position 1 at back		
Position	Signal	Function
1	0V	Digital input 0V
2	In	Digital input
3	F +	Digital output + (max 50Vdc - 0,1A)
4	F -	Digital output -

XSLAN-1XXX or XSLAN-2XXX or XSLAN-4200 2 positions terminal block : SHDSL1 & SHDSL2 & SHDSL3 & SHDSL4		
Position	Signal	Function
1	Line	SHDSL line
2	Line	SHDSL line

XSLAN-BP2XXX 2 positions terminal block : SHDSL1 by_pass & SHDSL2 by-pass		
Position	Signal	Function
1	Line	SHDSL line with by-pass feature
2	Line	SHDSL line with by-pass feature

XSLAN-BP4200 2 positions terminal block : SHDSL1 & SHDSL2 & SHDSL3 by_pass & SHDSL4 by-pass		
Position	Signal	Function
1	Line	SHDSL line (with by-pass feature on SHDSL3 and SHDSL4)
2	Line	SHDSL line (with by-pass feature on SHDSL3 and SHDSL4)

## INSTALLATION

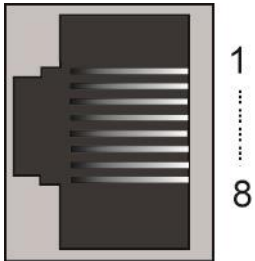
Ethernet RJ45 connector			
Position	Signal	Function	RJ45
1	Tx +	Emission polarity +	
2	Tx -	Emission polarity -	
3	Rx +	Reception polarity +	
4	N.C.	-	
5	N.C.	-	
6	Rx -	Reception polarity -	
7	N.C.	-	
8	N.C.	-	

XSLAN-X2220 2 positions terminal block : RS485		
Position	Signal	Function
1	A	RS485 polarity A
2	B	RS485 polarity B

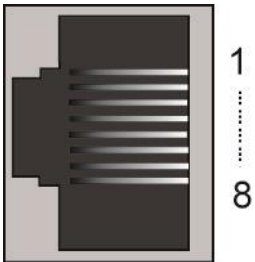
XSLAN-X2220 RJ45 connector : RS232 (To connect a DCE)				
Position	Signal	Direction	Function	RJ45
1	N.C.	-		
2	TD - 103	OUT	Data Emission	
3	RD - 104	IN	Data Reception	
4	N.C.	-		
5	SG - 102	-	Signal ground	
6	N.C.	-		
7	CTS - 106	IN	Clear to send	
8	RTS - 105	OUT	Request to send	

OUT = Signal supplied by the XSLAN

IN = Signal supplied by the external device

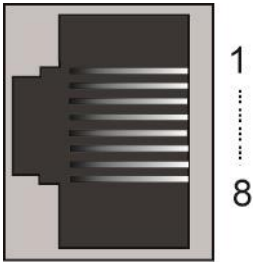
XSLAN-X2220 RJ45 connector : RS232 (To connect a DTE)				
Position	Signal	Direction	Function	RJ45
1	N.C.	-		
2	RD - 104	OUT	Data Reception	
3	TD - 103	IN	Data Emission	
4	N.C.	-		
5	SG - 102	-	Signal ground	
6	N.C.	-		
7	RTS - 105	IN	Request to send	
8	CTS - 106	OUT	Clear to send	

OUT = Signal supplied by the XSLAN





IN = Signal supplied by the external device



1.4 Push button

Push-button		
Pressing the PB	LED 	Function
During operation	Flashing red	Temporary return to the factory configuration. (IP address 192.168.0.128) The current configuration is not lost.
During power-up	Flashing red/green	Return to the factory configuration. The current configuration is deleted except if it has been saved into a file.

1.5 LED indicators

LED indicators Depending on models		
Function	LED	Description
<b>Power 1</b>		Steady green: The supply voltage 1 is present
<b>Power 2</b>		Steady green: The supply voltage 1 is present
<b>Run</b>		Steady green: The unit is ready Slow blinking green: The unit is busy Steady red: Startup (15 s) – Otherwise : product failure Fast blinking red: Firmware download in progress
<b>Ring</b>		Off: Fail safe ring disabled Steady green: The fail safe ring is established Steady red: Fail safe ring failure
<b>SHDSL 1 SHDSL 2 SHDSL 3 SHDSL 4</b>	<b>1 to 4</b>	Slow blinking green: SHDSL connection in progress Steady green: SHDSL connection established Flashing green: Traffic on the link
<b>Ethernet LAN 1 to 4</b>	<b>Lower LED</b>	Off: Not connected or interface disable Green: Connected Flashing green: traffic on the link
XSLAN-1220, XSLAN-2200, XSLAN-BP1220		
<b>RS232</b>	<b>Rx</b>	Characters received from the RS232 serial interface
	<b>Tx</b>	Characters transmitted to the RS232 serial interface
<b>RS485</b>	<b>Rx</b>	Characters received from the RS485 serial interface
	<b>Tx</b>	Characters transmitted to the RS485 serial interface

# INSTALLATION

## 2 Safety instructions

The product shall be installed in a fire electrical resistant cabinet by a qualified operator.

The product shall be connected only to equipment that complies with the IEC60950-1 or IEC62368-1 standards and that meets the following classifications:

- IEC60950-1 : Limited power circuits and SELV type – §2.2 and 2.5
- IEC62368-1 : ES1 & PS2



To avoid any risk of burns, it is strongly recommended to wear gloves to handle the product in operation when the ambient temperature exceeds 30 °C.

## 3 DIN rail mounting

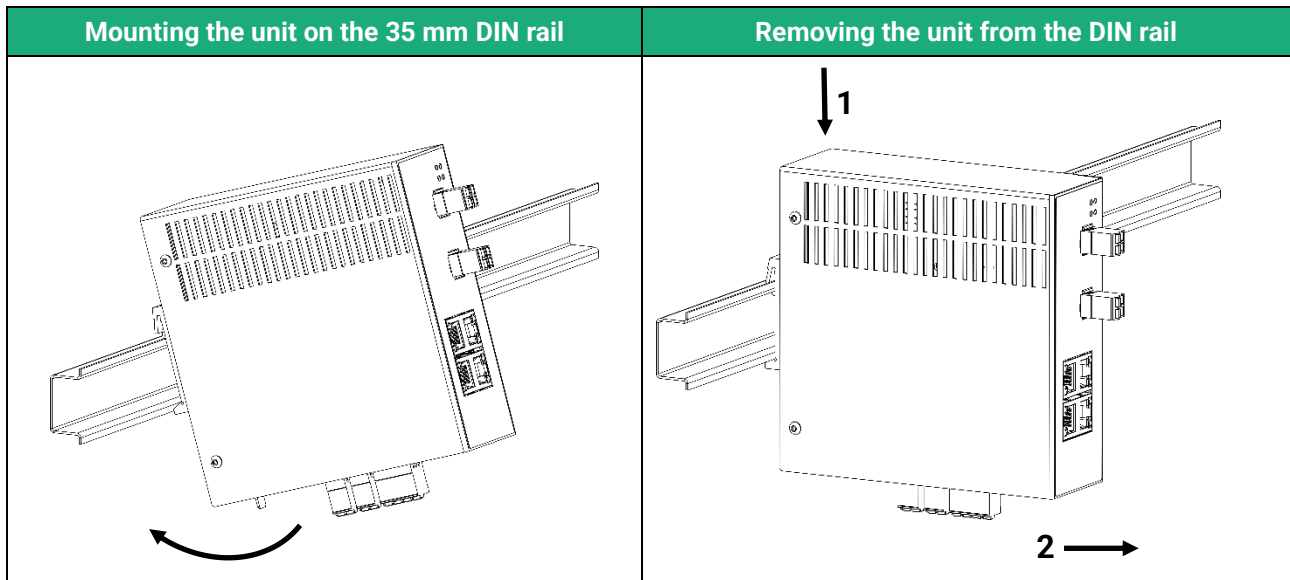

## 4 cooling

The product is designed to be mounted on a 35mm DIN rail.

To avoid obstructing the airflow around the unit, the spacing must be at least 25 mm above and below, and 10 mm left and right.

## 5 Power supply

The XSLAN provides a dual power inputs allowing a redundancy power supply.

The supply voltage must be regulated and strictly between 10 and 60 Volt DC (nominal: 12 – 48 VDC).

At power up the inrush current can reach 20 A for 100 µs.

## 6 Isolation and earthing

The enclosure of the XSLAN is metallic ; For safety and EMC reasons, the ground terminal (on the underside) must be connected to the protective earth of the installation.

The minus polarity of the supply voltage is common with the minus voltage of the electronic board (usually called 0V) and is isolated from the enclosure.

Ethernet and SHDSL signals are isolated through transformers. Consequently,

XSLAN-4200, XSLAN BP4200, XSLAN-X400, XSLAN-BP2400 and XSLAN-1400 models are electrically isolated from the outside up to a common mode voltage of 1500 V;

XSLAN-X220, XSLAN-BP2220 and XSLAN-1220 models are electrically isolated with the same conditions except for the RS232 and RS485 interfaces;

## 7 RS232 serial connection (XSLAN-X220)

Cables can be provided to connect the product to DTE and DCE as follows:

RS232 cables		
Reference	Connector	Function
CAB592	SubD 9 male	To connect a DCE to the product
CAB593	SubD 9 female	To connect a DTE to the product
CAB609	Wires	To connect a device providing a specific connector

The RS232 cable must be shorter than 10 meters.

## 8 RS485 serial connexion (XSLAN-X220)

The RS485 interface is not isolated.

Two 10 KOhm bus polarization resistors are included inside the product.

If the RS485 line is longer than 10 meters or if the data rate is greater than 19200 b/s, it is necessary to connect one 120 Ohm matching resistor at each end of the line and two 390 Ohm polarization resistors at one of the two extremities of the line

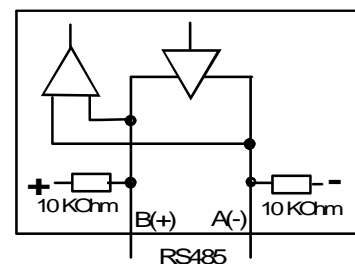

# INSTALLATION

## 9 Digital input and output

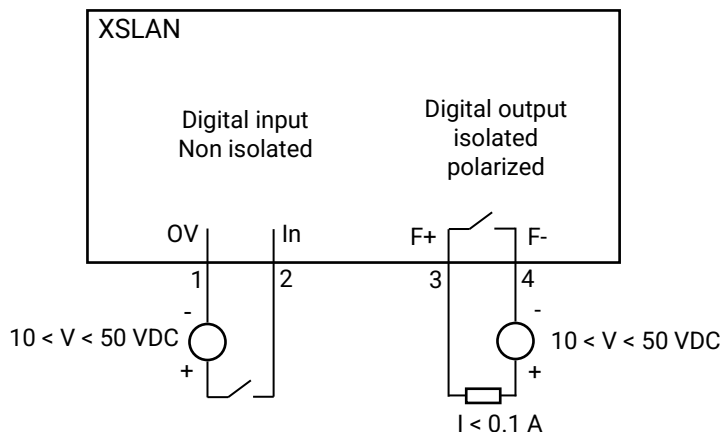

To check that the input and the output are correctly wired :

In the menu, select **Diagnostics > Hardware > Input/Output**

The status of the input is displayed and the output can be switched ON or OFF.

## 10 Preparing and checking the line

### 10.1 Type of cable

#### Twisted pair cable

The XSLAN SHDSL switch is designed to be connected to one or several telephone grade twisted pairs. The conductor diameter must be included between 0.4 mm and 1 mm.

A cable may be composed of several twisted pairs.

Each pair can usually be used for a different SHDSL transmission if necessary. However, care must be taken to ensure that crosstalk between pairs is not excessive.

#### Cable made of quads

It often happens that the twisted pairs of the same cable are wound in groups of two pairs; a group of two pairs rolled into each other is called a quad.

This type of cable is suitable. However, we will try to use only one pair per quad to avoid crosstalk (see below).

#### Shielded cable

It is better to use a shielded cable.

The shield must be connected to the earth at one of its ends.

The shield decreases the influence of the electromagnetic ambient noise on the SHDSL signal.

Moreover, the shield protects the XSLAN against lightning.

#### Electrical power cable

Two power conductors can be used instead of a twisted pair to set an SHDSL connection.

However, because the two wires are not twisted, the ambient electrical noise may disturb the transmission.

Compared to the transmission over a twisted pair, the maximum distance between two SHDSL switches is decreased.

### 10.2 Crosstalk interference

If the cable is made of several pairs, each pair can be used to transmit a particular SHDSL connection ; however the SHDSL signal transmitted in one pair may disturb the SHDSL signal transmitted in another one.

The closer the pairs, the greater the crosstalk. Thus the risk of crosstalk is higher between two pairs of the same quad. This is why, if the cable is made up of quads, it is advisable to avoid using the two pairs of the same quad.

### 10.3 Shield earthing

A shielded cable provides better noise immunity and surges protection during thunderstorms.

The best protection is provided when the shield is earthed at each end of the line. However, there may be a large potential difference between the connection points to the earth, especially when the line is long. Therefore, to avoid a large current flowing in the shield, it is recommended to connect the shield to the earth at only one end of the cable.

### 10.4 Protecting the SHDSL switch from lightning

The XSLAN is coupled to the line by a transformer which provides isolation between the circuit board and the line. Moreover, the XSLAN is equipped with internal protections against overvoltage.

However, if the line is vulnerable to thunderstorms, for example if it is an air line, or if it is several kilometers long, or if the installation is in a very exposed area, it is recommended to protect each XSLAN with a surge protector, as described below.

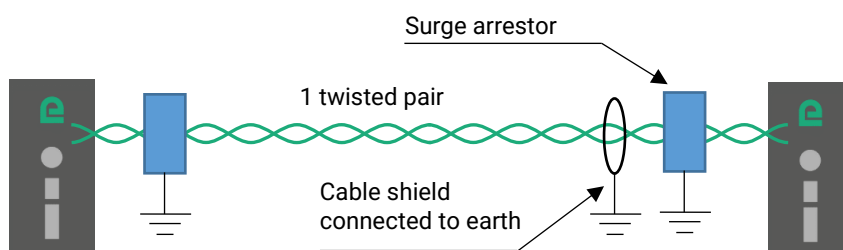

## 11 Connecting the XSLAN to the line

### 11.1 General precautions

The SHDSL signal is not polarized ; it is why the two conductors of one line can be inverted. Check that the shield, if any, is properly connected to the ground.

### 11.2 Point to point connection using two, three or four twisted pairs

An aggregated link is a link between two XSLAN that uses two or three or four twisted pairs to multiply the total throughput (depending on model).

When performing a point to point link to doubled (XSLAN-2XXX) or tripled or quadrupled (XSLAN-4200) the data rate, it is recommended to wire pairs in an orderly way, as shown below, to make the configuration and the diagnostic easier.



# INSTALLATION

## 11.3 Daisy chain or ring connection

If the SHDSL switches are connected to shape a daisy chain network or a ring network, we recommend to connect the lines as shown below.

In that way, the configuration of each SHDSL switch will be similar.

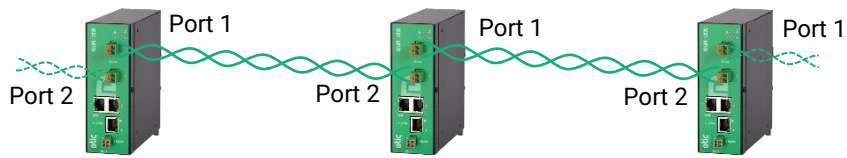

# PREPARING THE SETUP

## 1 Connecting a PC for configuration

### 1.1 Overview

The XSLAN is configured using a PC with an HTML browser. No additional software is required.

**Online help:**

For most pages of the administration server an help page is available by clicking [?](#) located at the top right of the page.

**Administration server address:**

When the product is delivered, the IP address of the administration web server is 192.168.0.128.

**First setup:**

For the first configuration, we advise to connect the PC directly to the Ethernet LAN port. Subsequent changes can be made remotely.

**Restoring the factory IP address:**

The factory IP address 192.168.0.128 can be restored (see the User guide of the product).

**Restricted access to the administration server:**

If you do not have access to the administration server, it is probably that access has been restricted for security reasons or for other reasons.

**Network IP address:**

Later in the text, we often speak of “network IP address”. We mean the lowest value of the addresses of the network.

For instance, if the netmask of a network is 255.255.255.0, the network IP address of that network is terminated by a zero (X.Y.Z.0.).

**Characters allowed:**

Accented characters are not supported.

# PREPARING THE SETUP

## 1.2 First configuration

### Step 1: Create or modify the PC TCP/IP connection

Assign to the PC an IP address different but consistent with the factory IP address of the XSLAN. For the first configuration, assign for instance 192.168.0.1 to the PC.

### Step 2: Connect the PC to the XSLAN

Connect the PC directly to the XSLAN with any Ethernet cable (straight or cross-wired);

### Step 3: Launch the web browser

Launch the web browser and then enter the IP address of the XSLAN: 192.168.0.128

The Home page of the administration server is displayed.

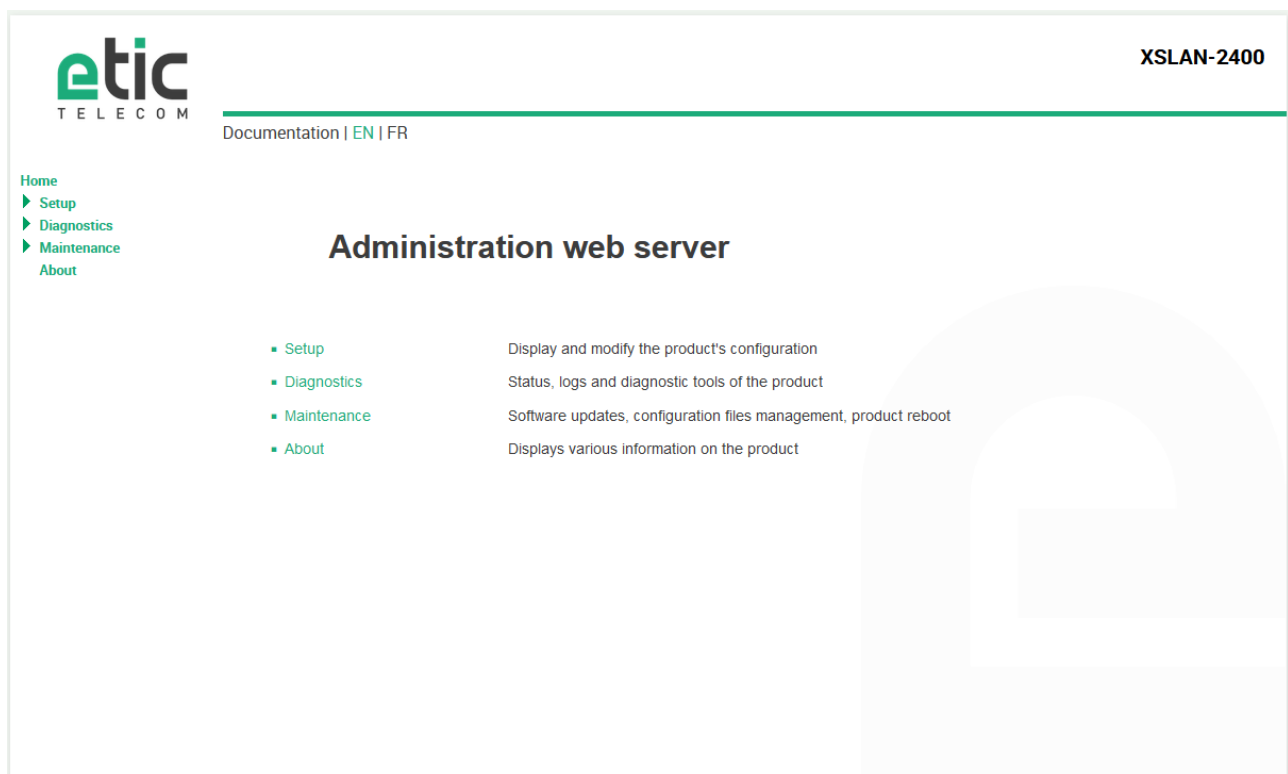

**Note :** Access to the administration server is not protected when configuring the XSLAN for the first time.

## 1.3 Modification ultérieure de la configuration

Thereafter, the XSLAN administration server is accessible from the Ethernet interface or remotely through the SHDSL line at the IP address assigned to the product.



## 2 Temporary return to the factory settings

If the IP address of the XSLAN could not be founded, or if it is impossible to access the administration server, for example, following a bad VLAN configuration, it is possible to restore the factory settings without losing the current configuration.

- Press the push-button located on the back, for example with a small screwdriver
- Keep the push-button pressed for about 3 seconds;
- The LED  blinks red rapidly
- The administration server becomes accessible at the factory IP address (192.168.0.128), in HTTP without a password. The factory configuration is temporarily running. However, the current configuration is not lost and it is the one that is still displayed in the pages of the Administration Server.
- After reading the IP address or changing some parameters, press again the push button or reboot the product.
- The product can be reached at the registered IP address.

Note :

If the IP address of the XSLAN is unknown, the software tool **EticFinder** can be used.

This software detects all ETIC branded products on a local network. After starting the software, click on the "Search" button, and when the product list is displayed, double-click on the product address to access the html server.

## 3 Restoring the factory settings

It is possible to restore the factory configuration permanently using the push button on the rear panel, or by using the administration server. In this case, the current configuration will be lost unless it has been saved to a file.

**To restore the factory settings using the push button,**

- Power off the XSLAN,
- Press the push-button, for example with a small screwdriver,
- Power on the XSLAN, while keeping the push-button pressed at least 30 s.

The LED  blinks red/green; the XSLAN boots and the factory configuration is restored.

Note : The factory configuration can also be restored via the menu **Maintenance > Configurations management** of the administration server.

## PREPARING THE SETUP

### 4 Protecting the access to the administration server

- In the menu, choose **Setup > Security > Administration rights**
- Enter a user name and password to protect the administration server.
- Tick the **Password protect the web site access** checkbox

If the username and password to access the administration server are lost, you have to temporarily return to the factory settings; access to the administration server is then free.

### 5 Configuration steps

To configure the product, we advise to proceed as follows :

- Set up the LAN interface
- Set up the SHDSL connections
- Set up the RSTP or failsafe ring redundancy protocol
- Set up VLAN
- Set up SNMP
- Set up QoS
- Set up the routing functions
- Set up the serial gateways

For detail about the configuration and the diagnostics, refer to the XLAN/XSRACK/XSMIL Setup Guide :  
Reference : Reference : "DOC\_DEV\_XS\_Setup guide\_x"

## ANNEX 1 : SHDSL data rate versus distance

The table below shows the data rate which is possible to get on a SHDSL link depending on the wire diameter and the distance.

These values are indicative in noise free environment.

<b>Data rate</b>	192Kb/s	1,2Mb/s	2,3Mb/s	5,7 Mb/s	6.7 Mb/s	10 Mb/s	12 Mb/s	15 Mb/s
<b>Distance (Ø 0.9 mm) *</b>	13 km	8 km	6 km	3.7 km	2.5 km	1.5 km	1 km	0.7 km
<b>Distance (Ø 0.4 mm) *</b>	7 km	4 km	3 km	2 km	1.3 km	0.9 km	0.6 km	0.4 km



405 rue Lavoisier  
38330 Montbonnot Saint Martin  
France

Tel : +33 (0)4 76 04 20 00  
contact@etictelecom.com

[www.etictelecom.com](http://www.etictelecom.com)