



## RS485 Line isolator

### Si485

Document ref. : 9012509-02

13, Chemin du Vieux Chêne  
38240 Meylan - France  
Tél : +33 4 76 04 20 00  
Fax : +33 4 76 04 20 01  
E-mail : info@etictelecom.com  
Web : [www.etictelecom.com](http://www.etictelecom.com)

### PROFIBUS DP Polarisation / Matching RS485

The 2 isolators on each end of the line :

- Switch 2 or 3 placed ON
- Switches 5 and 6 ON
- All others OFF

Other isolators on the line :

- All switches OFF

### MODBUS Polarisation / matching RS485

The 2 isolators on each end of the line :

- Switch 2 placed ON
- Switches 5 and 6 placed ON
- All others OFF

Other isolators on the line :

- All switches OFF

### UNITELWAY Polarisation / Matching RS485

The 2 isolators on each end of the line :

- Switch 4 placed ON
- All others OFF

Other isolators on the line :

- All switches OFF

The RS485 line isolator, reference Si485, allows to insulate a RS485 network (Nr 1) from another RS485 network (Nr 2).  
The RS485 interface Nr 1 is optically isolated from the interface Nr 2; the voltage of the polarisation Resistors of the interface Nr 2 is isolated from the supply voltage of the product.  
Each RS485 line can be matched and polarised by the 6 microswitches.  
No adjustment of the data rate or frame is necessary.

#### Pin . Signal

1	B(+)	RS485 isolated line / polarity B (Nr 1)
2	A(-)	RS485 isolated line / polarity A (Nr 1)
3	B(+)	RS485 polarity B (Nr 2)
4	A(-)	RS485 polarity A (Nr 2)
5	NC	Not connected
6	NC	Not connected
7	POWER +	9 to 40 V DC supply voltage
8	POWER -	Signal ground

#### Switches

1	Line matching resistor 620 $\Omega$
2	Line matching resistor 150 $\Omega$ (Profibus DP type A / Modbus)
3	Line matching resistor 220 $\Omega$ (Profibus DP type B)
4	Line matching resistor 120 $\Omega$ + 1 nF (Unitelway)
5	Polarisation resistor 390 $\Omega$ on B (+)
6	Polarisation resistor 390 $\Omega$ on A (-)

## Overview

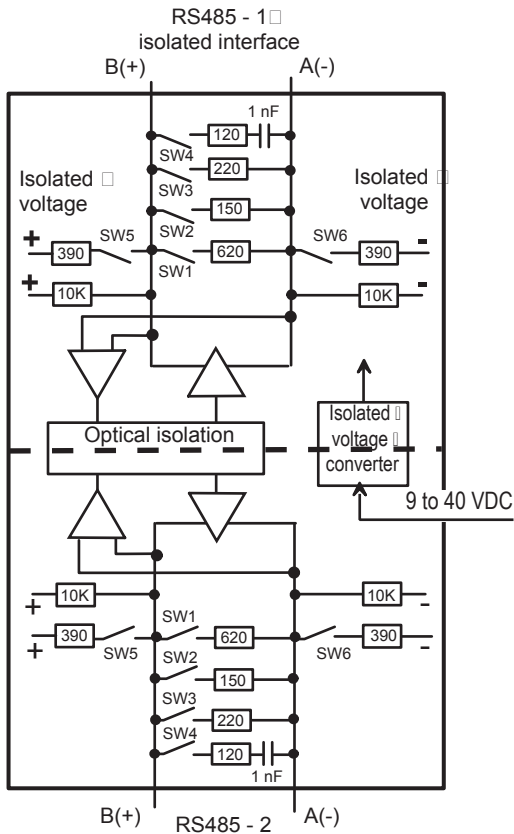

### Line cable

It must be a «twisted pair» with a characteristic impedance of 120 Ω. The range of transmission will increase the larger the diameter of the cable and the lower the mutual capacitance between the two wires.

### Cable shield

To avoid signal disruption, the twisted pair should be equipped with a shield.

The shield must only be connected to earth at one end.

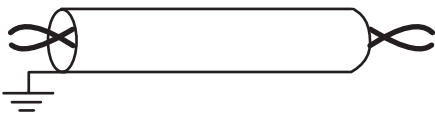

### Maximum common mode allowed

The maximum common mode voltage is 2500 V.

## Power supply

The power supply voltage must be between 9 and 40 VDC.

**Using a voltage above 40 VDC is destructive.**

The circuit board is equipped with a device protecting it against an inversion of polarity and a fuse which automatically renews itself.

Characteristics	
Dimensions	72 x 45 x 105 mm (h, l, d)
Isolation	2500 V common mode
Electrical security	EN 60950
Power supply	9 to 40 VDC (min and max voltage)
Consumption	50 mA at 24 VDC
Operating temperature	-20°C / + 60°C dry air
RS485 Interfaces	<ul style="list-style-type: none"> <li>2-wire RS485 on a screw terminal</li> <li>Number of subscribers on each line : 32</li> </ul>
Type of data transmitted	<ul style="list-style-type: none"> <li>Asynchronous data</li> <li>All data rates / frames up to 500 kb/s</li> </ul>
Configuration	By switches Line polarisation and matching resistors

### Connection to the RS485 lines

32 subscribers maximum, can be connected to each RS485 line. If we call the two wires of one line «wire A» and «wire B», you should take care to connect «wire A» to RS485 signal «A» of each subscriber, and wire B to RS485 signal «B» of each subscriber.

### Polarisation and matching of the RS485 line

An RS485 line must end with a matching resistor (or an impedance) at each one of its ends.

It must also be polarised by 2 polarisation resistors.

The norms relative to each protocol (Profibus, modbus..) define the value of the matching and polarisation resistors as well as the way to implement the polarisation resistors (either on each subscriber or only on each end of the line).

The switches allow the activation of the matching and polarisation resistors; the main uses are shown below.

